

Southwest Calgary Ring Road

Traffic Advisory

November 29, 2019

Traffic Realignment Between Highway 8, Sarcee Trail and Glenmore Trail

Location: Highway 8, Sarcee Trail and Glenmore Trail

Impacts:

- Realignment of traffic through a portion of the new interchange at Sarcee Trail and Glenmore Trail
- Occasional traffic stoppages to allow the transition and opening of new roadways
- Sarcee Trail intersection realignment

Reason: Shifting traffic onto new roads and bridges in order to construct permanent lanes of SWCRR

Implementation Date: December 6th, 2019 from 10 p.m. to 6 a.m.

Speed limit: 60 km/h

Other information: Guide signs will be installed to guide the new flow of traffic.

For your safety, please obey all construction signs when travelling through the area. KGL would like to thank you for your patience during this period of construction.

403-212-0565
info@SWCRRproject.com
www.SWCRRproject.com



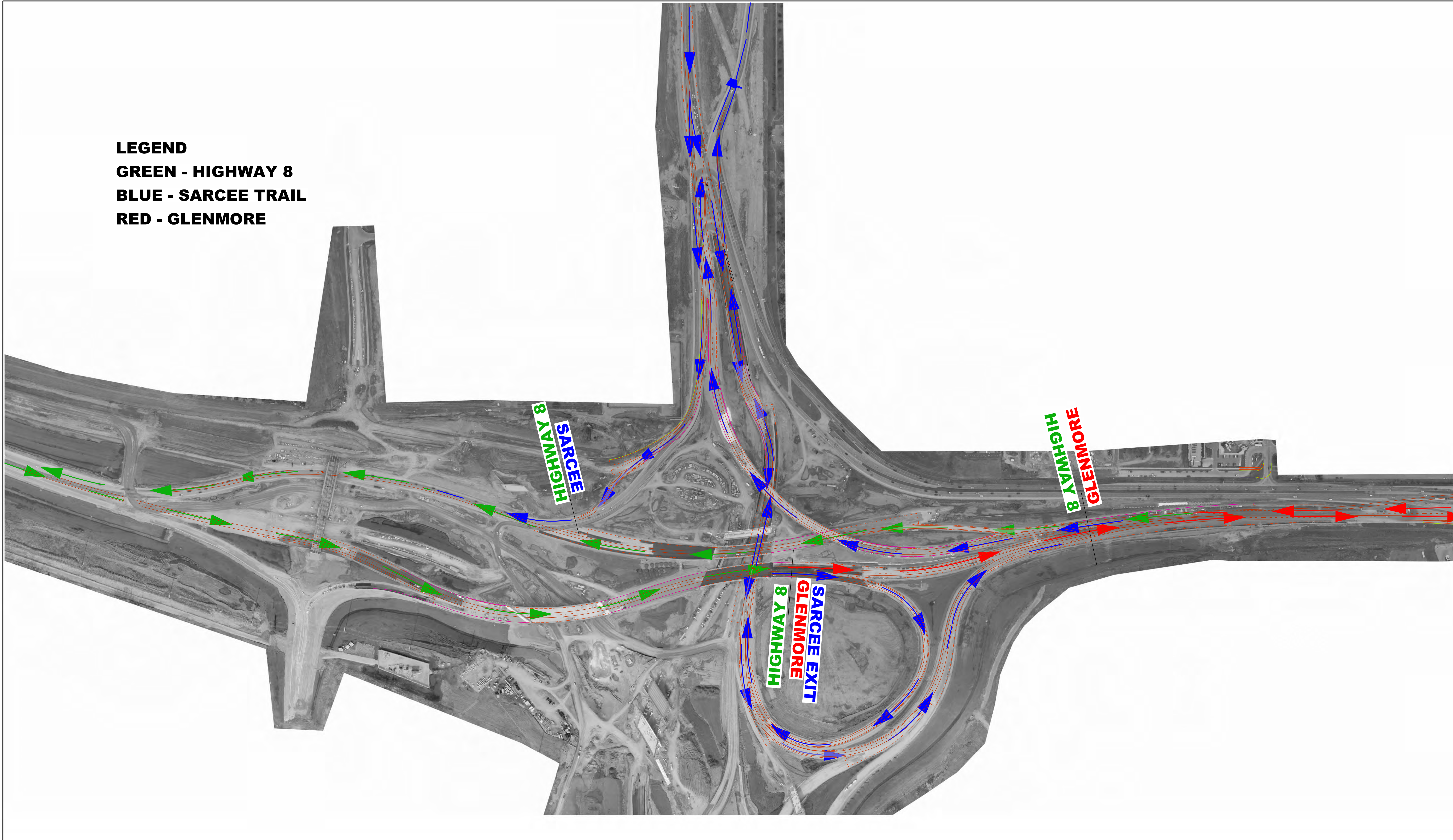

DESIGN DATE (SUBGRADE SURFACE) BY DATE SURVEYED PHOTO DESCRIPTION CONTRACT 16944 HIGHWAY 201:06 DRAWING

LEGEND
GREEN - HIGHWAY 8
BLUE - SARCEE TRAIL
RED - GLENMORE



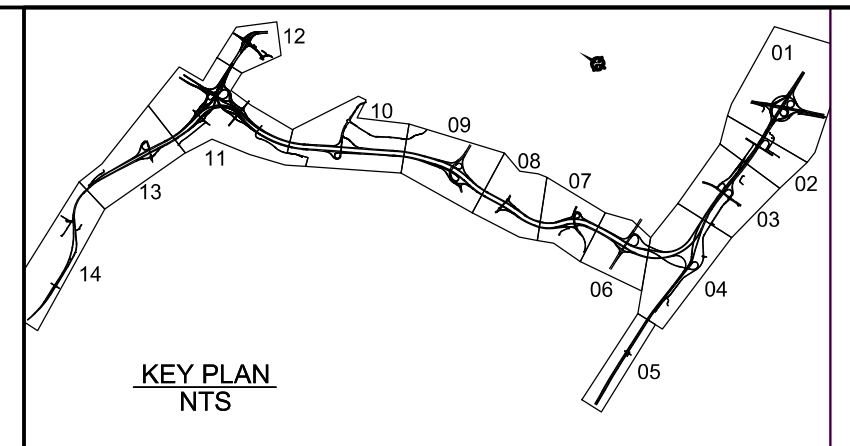

1. ALL MEASUREMENTS IN METERS (m) UNLESS OTHERWISE SPECIFIED.
 2. ALL COORDINATES SHOWN ARE GEODETIC NAD 83, ON 3-DEGREE TRANSVERSE MERCATOR (3TM) MAPPING PLAN.





CONSULTANT

 JOB No. 476002

LEGEND

DETOUR LINSTYLES & SYMBOLS TO MATCH DESIGN PACKAGE 40 00_GE_002

HIGHWAY 8 TRAFFIC  

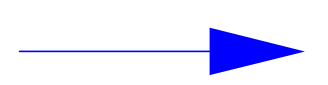
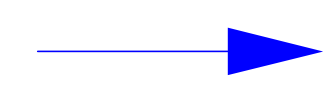
GLENMORE TRAFFIC  

SARCEE TRAFFIC  

REV	DATE	REVISION	BY

Alberta Transportation
 HWY 201:06
 SOUTHWEST CALGARY RING ROAD
 TRAFFIC FLIP ADVISORY
 WINTER 2019 / 2020

CONTRACT	HIGHWAY	SHEET	DRAWING
16944	201:06	OF	-

SPFILES